

4X



2X



2X



1.

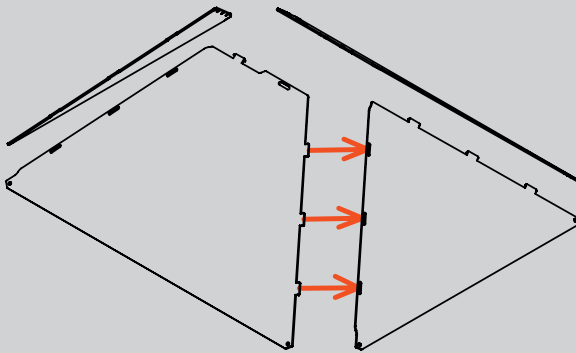

2.

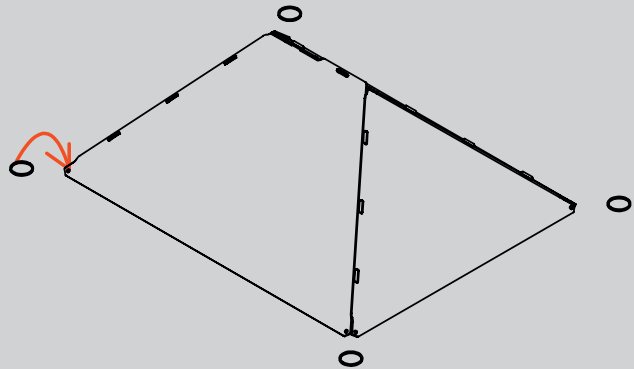

3.

